

# Commercial Building & Restoration, Inc.

Commercialbuildrestoration.com  
Office 718-369-1001 Fax 718-369-7059

03/28/23

513 12 Street Owners Group  
513 12<sup>th</sup> Street  
Brooklyn, NY 11215

Rimkus New York PLLC.  
77 Water Street  
Suite 836  
New York, NY 10005  
Tel: 866-299-3370

**513 12<sup>th</sup> Street, Brooklyn, NY 11215**  
**Facade Repairs**  
**Mobilization work in progress**



**DOB work permit and TPP posted on the front door**

119 14<sup>th</sup> St, BROOKLYN NY 11215  
(718) 369-1001 F (718) 369-7059

# Commercial Building & Restoration, Inc.

Commercialbuildrestoration.com  
Office 718-369-1001 Fax 718-369-7059

**Approved DOB Drawings**

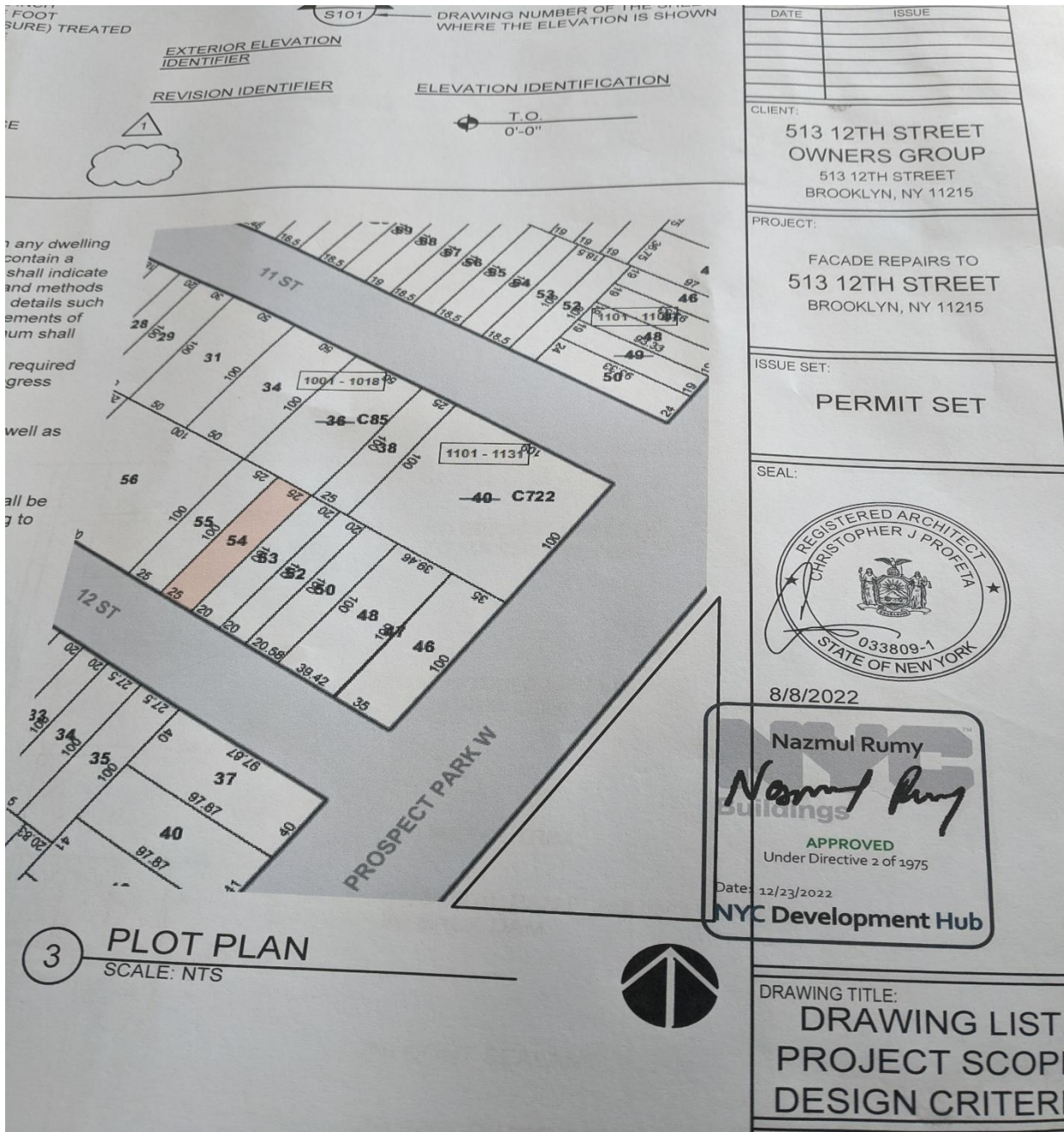

119 14<sup>th</sup> St, BROOKLYN NY 11215  
(718) 369-1001 F (718) 369-7059

# Commercial Building & Restoration, Inc.

Commercialbuildrestoration.com  
Office 718-369-1001 Fax 718-369-7059

**Approved CD5**

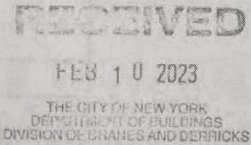
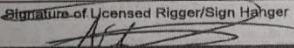
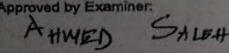
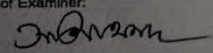
		<div style="border: 1px solid black; padding: 2px;">                 File Representative—Last Name                  Andrade Lopez  Forde Febo             </div>	
		CD5: Suspended Scaffold Application <i>File 3 copies / Application must be typewritten</i>	
<b>1 Application Type</b> <input checked="" type="checkbox"/> Initial <input type="checkbox"/> Amendment <input type="checkbox"/> Renewal <input type="checkbox"/> This is an Industrial Roped Access Job <input type="checkbox"/> This is a Site Safety Job			
<b>2 Location Information</b> Borough Brooklyn      Block 6133      Lot 7501 Address 513 12th Street      Number of Stories 8			
<b>3 Filing Representative Information</b> Name Andrade / Lopez / Forde / Febo      Registration # 3844 / 3953 / 8082 / 8065 Business Name Rigging Consultants Inc. Address 555 Longfellow Avenue      City Bronx      State NY      Zip 10474 Phone 718-292-0099      Fax      E-Mail manny@riggingconsultants.com			
<b>4 Rigger/Sign Hanger Information</b> Name Ataf A. Nawaz      License # 6570 Business Name Commercial Bdg Rest. Address 119 14th Street      City Brooklyn      State NY      Zip 11215 Phone 718-369-1001      Fax      E-Mail commercialbuildingrichie@gmail.com			
<b>5 Owner or Managing Agent Information</b> Name Gisela Starton      Title VP Business Name 513 12th Street Owners Corp Address 5 Brewster Street #179      City Glen Cove      State NY      Zip 11542 Phone 646-483-7304      Fax      E-Mail Starton @513Owners.com			
<b>6 Job Information</b> Description of Work to be Performed: Facade Restoration     Expected Start Date: Upon Approv      Approximate Duration of Job: 1 Year		Date Submitted Stamp  <div style="text-align: center;">  </div>	
<b>7 Statements and Signatures</b> I certify that the subject work and setup of equipment will be done under my supervision or under the supervision of Ataf A. Nawaz (Supervisor, Foreman, or Rigger/Sign Hanger). The work will be done in a safe and workman-like manner. Falsification of any statement is a misdemeanor and is punishable by a fine or imprisonment, or both. It is unlawful to give to a city employee, or for a city employee to accept, any benefit, monetary or otherwise, either as a gratuity for properly performing the job or in exchange for special consideration. Violation is punishable by imprisonment or fine or both. I understand that if I am found after hearing to have knowingly or negligently made a false statement or to have knowingly or negligently falsified or allowed to be falsified any certificate, form, signed statement, application, report or certification of the correction of a violation required under the provisions of this code or of a rule of any agency, I may be barred from filing further applications or documents with the Department.			
Name of Licensed Rigger/Sign Hanger (please print) Ataf A. Nawaz		Signature of Licensed Rigger/Sign Hanger 	
		Date 02/06/2023	
<b>Internal Use Only</b> Approved by Examiner: 		FEB 13 2023      SR23/0308 THE CITY OF NEW YORK DEPARTMENT OF BUILDINGS DIVISION OF CRANES AND DERRICKS	
Signature of Examiner: 		Expiration Date: 05/01/23	

CD5 12/14

119 14<sup>th</sup> St, BROOKLYN NY 11215  
(718) 369-1001 F (718) 369-7059

# Commercial Building & Restoration, Inc.

Commercialbuildrestoration.com  
Office 718-369-1001 Fax 718-369-7059

## Staging area

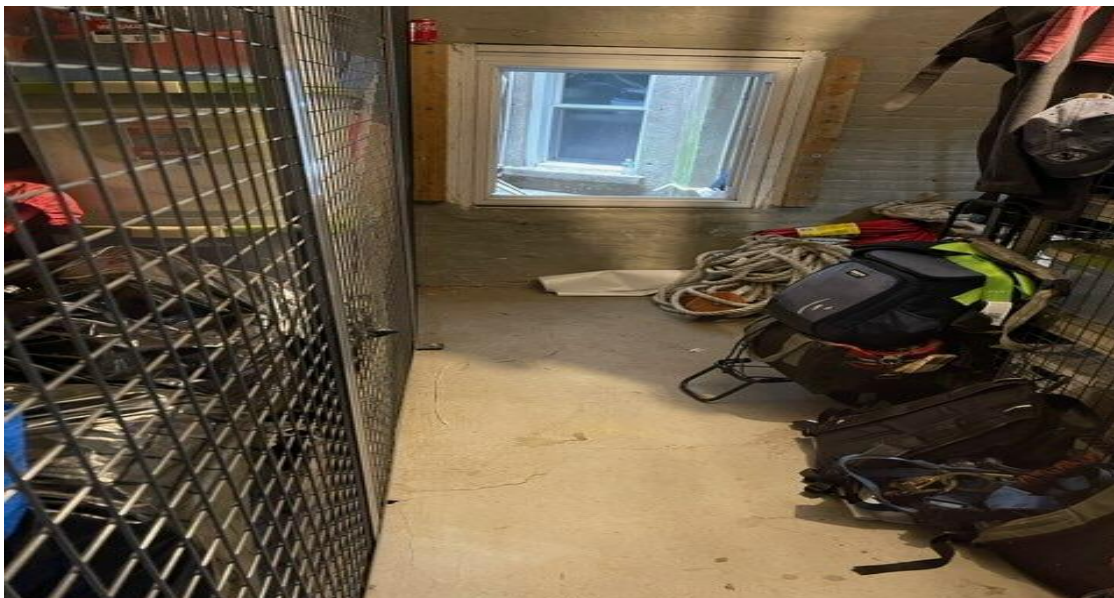

119 14<sup>th</sup> St, BROOKLYN NY 11215  
(718) 369-1001 F (718) 369-7059

# Commercial Building & Restoration, Inc.

Commercialbuildrestoration.com

Office 718-369-1001 Fax 718-369-7059



**Material Hoist installed**



119 14<sup>th</sup> St, BROOKLYN NY 11215  
(718) 369-1001 F (718) 369-7059

# Commercial Building & Restoration, Inc.

Commercialbuildrestoration.com  
Office 718-369-1001 Fax 718-369-7059

**Outrigger installation work in progress**



119 14<sup>th</sup> St, BROOKLYN NY 11215  
(718) 369-1001 F (718) 369-7059

# Commercial Building & Restoration, Inc.

Commercialbuildrestoration.com  
Office 718-369-1001 Fax 718-369-7059



**Anchor plates installed awaiting pull test Thursday 3/30/23**



119 14<sup>th</sup> St, BROOKLYN NY 11215  
(718) 369-1001 F (718) 369-7059

# Commercial Building & Restoration, Inc.

Commercialbuildrestoration.com  
Office 718-369-1001 Fax 718-369-7059

**Scaffold almost ready**



119 14<sup>th</sup> St, BROOKLYN NY 11215  
(718) 369-1001 F (718) 369-7059



# Commercial Building & Restoration, Inc.

Commercialbuildrestoration.com  
Office 718-369-1001 Fax 718-369-7059

**Cutting work in progress**



119 14<sup>th</sup> St, BROOKLYN NY 11215  
(718) 369-1001 F (718) 369-7059

# Commercial Building & Restoration, Inc.

Commercialbuildrestoration.com  
Office 718-369-1001 Fax 718-369-7059

**Pull test passed**

Customer: Commercial Building Restoration  
Location: 513 12<sup>th</sup> Street, Brooklyn, NY  
Test: Post Installed Anchor Pull Test  
Date: March 30<sup>th</sup>, 2023

**PCS ENGINEERING**  
93 Madison Avenue  
Valhalla, New York 10595

On March 30<sup>th</sup>, 2023, PCS was on site to perform anchor pull testing in accordance to NYC Buildings Bulletin 2016-005. Special inspections shall be performed in accordance with the NYC Building Code and 1 RCNY 101-06. All anchors are randomly tested and subjected to a confined tension test.

**Findings:** 5/8" threaded rod expansion anchors were tested at 513 12<sup>th</sup> street, Brooklyn, NY on March 30<sup>th</sup>, 2023. Anchors were installed at the side courtyard into brick masonry. There is a total 8, 5/8" threaded rod anchors located along the side courtyard. 20% of each post installed anchor design is required to be tested per NYC Buildings Bulletin 2016-005. 3 - 5/8" threaded rod anchors were tested by confined tension tests.

**Results: PASSED**

No.	Anchor	Anchor Embedment	Anchor Location	Test Date and Time	Test Load	Results
1	5/8" threaded rod, HiTi HY 270 Epoxy	Brick Masonry	Side Courtyard	3/30/23 2:45 PM	2,500 lbs, 1 minute	PASSED
2	5/8" threaded rod, HiTi HY 270 Epoxy	Brick Masonry	Side Courtyard	3/30/23 2:54 PM	2,500 lbs, 1 minute	PASSED
3	5/8" threaded rod, HiTi HY 270 Epoxy	Brick Masonry	Side Courtyard	3/30/23 3:05 PM	2,500 lbs, 1 minute	PASSED

PCS Engineering, PLLC  
93 Madison Ave, Valhalla New York

1 of 1

**Electrical permit for panel box**

**NYC Buildings**

**Work Permit Department Of Buildings**

Permit Number: B00853833-11-EL      Issued: 04/03/2023      Expires: 07/08/2023  
Address: 513 12 STREET 11215      Issued To: JOSEPH BONURA  
Business: SWITCH ELECT OF THE FIVE  
License No: 010515

Description: Minor Work  
Minor work hand tool outlet basement

For detailed information regarding this permit, please log on to DOB NOW at [www.nyc.gov/buildings](http://www.nyc.gov/buildings).  
Call 311 with any questions or complaints.

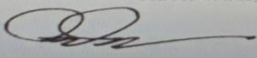
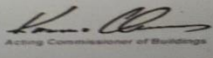
Borough Commissioner:       Commissioner of Buildings:   
Acting Commissioner of Buildings

Tampering with or knowingly making a false entry in or falsely altering this permit is a crime that is punishable by a fine, imprisonment or both.

119 14<sup>th</sup> St, BROOKLYN NY 11215  
(718) 369-1001 F (718) 369-7059

# Commercial Building & Restoration, Inc.

Commercialbuildrestoration.com  
Office 718-369-1001 Fax 718-369-7059

**Approved bricks “Patriot & 53 DD STD” to be mixed**

**Profeta, Christopher**

Fri, Mar 31, 1:25 PM  
(4 days ago)

to me, James, Richie, Mauricio

Hi all, sorry I've been in the field and traveling for the past few days. As far as the brick goes, are you able to mix the two as it seems to be that way on the existing wall.

Christopher Profeta  
Practice Leader

**Electrical panel installed**



# Commercial Building & Restoration, Inc.

Commercialbuildrestoration.com

Office 718-369-1001 Fax 718-369-7059



119 14<sup>th</sup> St, BROOKLYN NY 11215  
(718) 369-1001 F (718) 369-7059

# Commercial Building & Restoration, Inc.

Commercialbuildrestoration.com  
Office 718-369-1001 Fax 718-369-7059

**Misc damaged brick removal and replacement. Contract total is 50**



119 14<sup>th</sup> St, BROOKLYN NY 11215  
(718) 369-1001 F (718) 369-7059

# Commercial Building & Restoration, Inc.

Commercialbuildrestoration.com  
Office 718-369-1001 Fax 718-369-7059

**New Bricks 9 of 50**



119 14<sup>th</sup> St, BROOKLYN NY 11215  
(718) 369-1001 F (718) 369-7059

# Commercial Building & Restoration, Inc.

Commercialbuildrestoration.com  
Office 718-369-1001 Fax 718-369-7059

## Pointing work



119 14<sup>th</sup> St, BROOKLYN NY 11215  
(718) 369-1001 F (718) 369-7059

# Commercial Building & Restoration, Inc.

Commercialbuildrestoration.com  
Office 718-369-1001 Fax 718-369-7059



**10 bricks removed & replaced – Total is 19 of 50**



119 14<sup>th</sup> St, BROOKLYN NY 11215  
(718) 369-1001 F (718) 369-7059



# Commercial Building & Restoration, Inc.

Commercialbuildrestoration.com

Office 718-369-1001 Fax 718-369-7059



119 14<sup>th</sup> St, BROOKLYN NY 11215  
(718) 369-1001 F (718) 369-7059

# Commercial Building & Restoration, Inc.

Commercialbuildrestoration.com  
Office 718-369-1001 Fax 718-369-7059

**Additional 31 Bricks removed and replaced. The total contract amount is 50. The total amount of bricks removed and replaced is 50.**



119 14<sup>th</sup> St, BROOKLYN NY 11215  
(718) 369-1001 F (718) 369-7059

# Commercial Building & Restoration, Inc.

Commercialbuildrestoration.com  
Office 718-369-1001 Fax 718-369-7059



119 14<sup>th</sup> St, BROOKLYN NY 11215  
(718) 369-1001 F (718) 369-7059

# Commercial Building & Restoration, Inc.

Commercialbuildrestoration.com  
Office 718-369-1001 Fax 718-369-7059

## Parapet wall work in progress



119 14<sup>th</sup> St, BROOKLYN NY 11215  
(718) 369-1001 F (718) 369-7059

# Commercial Building & Restoration, Inc.

Commercialbuildrestoration.com  
Office 718-369-1001 Fax 718-369-7059

**Protection installed**

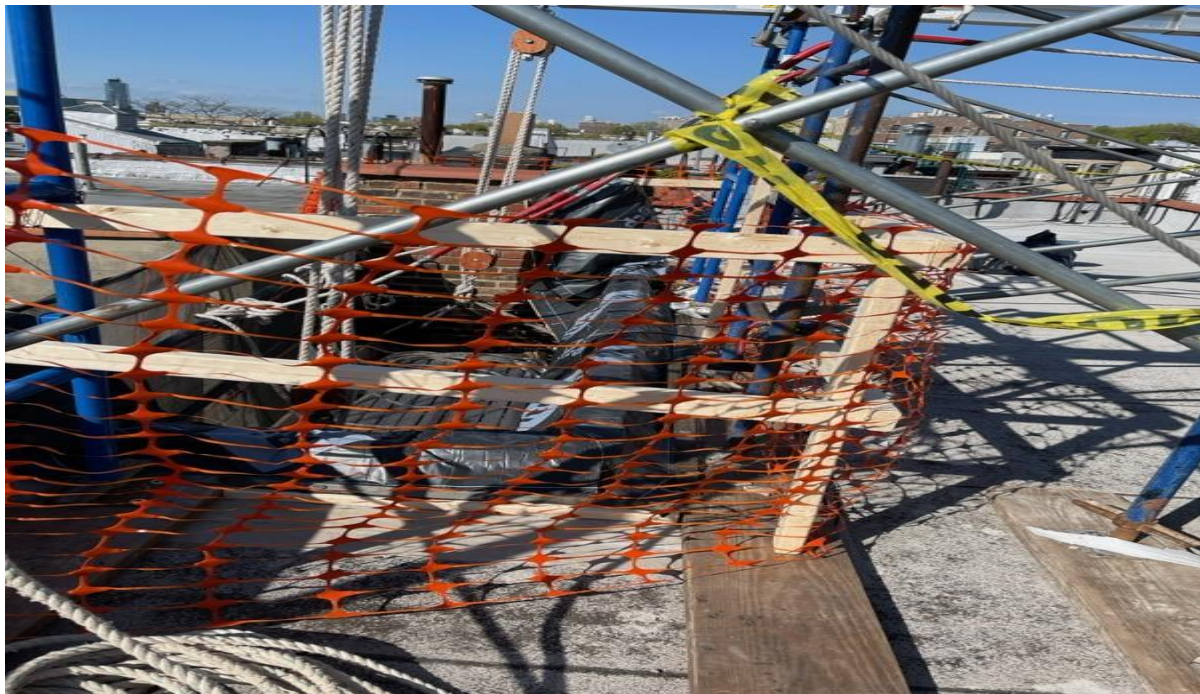

119 14<sup>th</sup> St, BROOKLYN NY 11215  
(718) 369-1001 F (718) 369-7059

# Commercial Building & Restoration, Inc.

Commercialbuildrestoration.com  
Office 718-369-1001 Fax 718-369-7059

**Brick removal work in progress**



**Stucco work in progress**

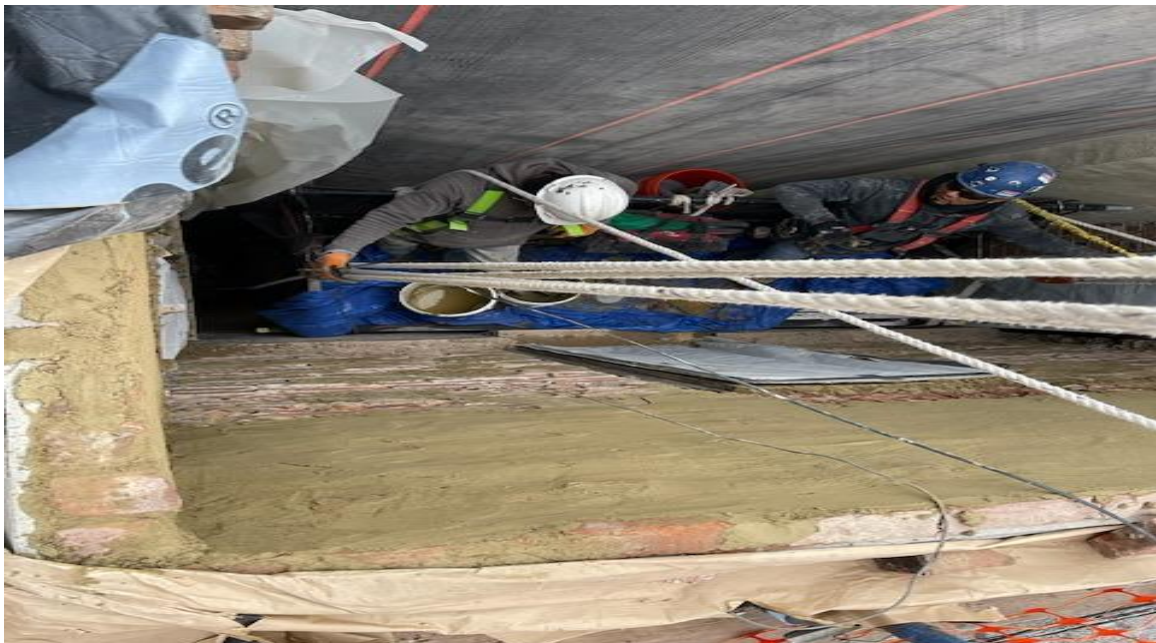

119 14<sup>th</sup> St, BROOKLYN NY 11215  
(718) 369-1001 F (718) 369-7059

# Commercial Building & Restoration, Inc.

Commercialbuildrestoration.com  
Office 718-369-1001 Fax 718-369-7059



119 14<sup>th</sup> St, BROOKLYN NY 11215  
(718) 369-1001 F (718) 369-7059

# Commercial Building & Restoration, Inc.

Commercialbuildrestoration.com  
Office 718-369-1001 Fax 718-369-7059

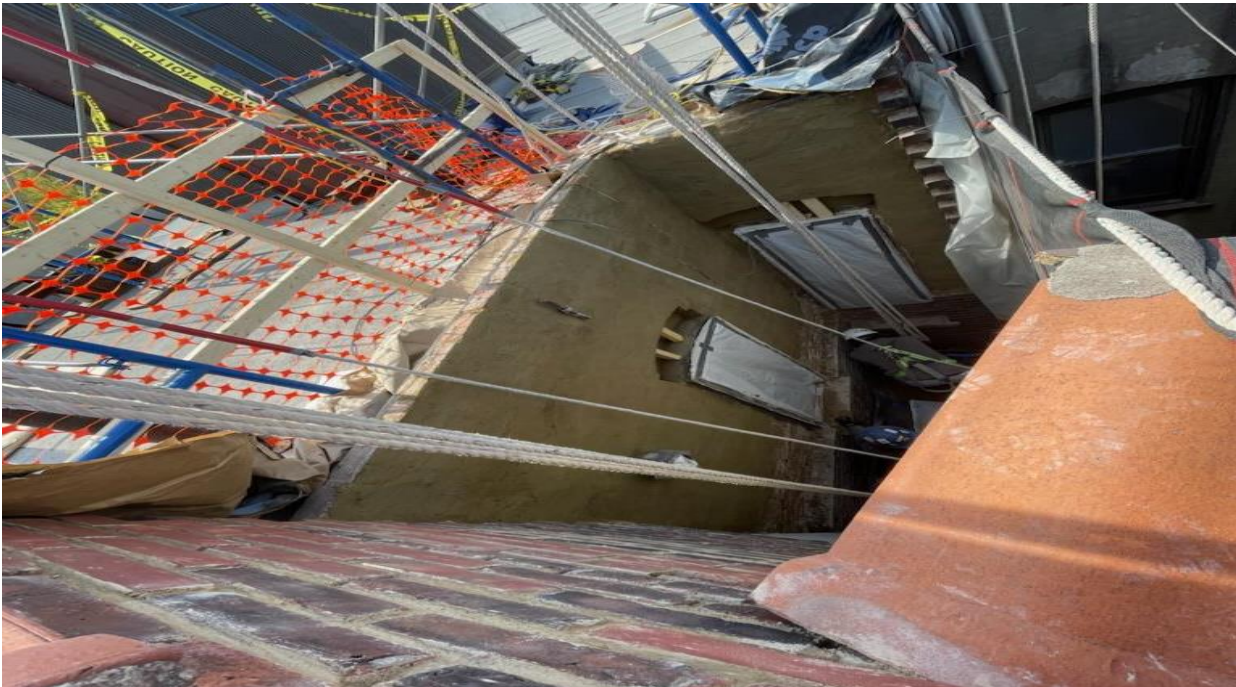

**All contracted brick removal is done 100% and all new bithuthane is installed**



119 14<sup>th</sup> St, BROOKLYN NY 11215  
(718) 369-1001 F (718) 369-7059



# Commercial Building & Restoration, Inc.

Commercialbuildrestoration.com  
Office 718-369-1001 Fax 718-369-7059

**Brickwork removed to the 4<sup>th</sup> floor window sill as per our contract**



**4<sup>th</sup> floor window sill**

**New approved brick work in progress**



# Commercial Building & Restoration, Inc.

Commercialbuildrestoration.com

Office 718-369-1001 Fax 718-369-7059



**Brick ties (every 14-16" on center) with continuous wire**



# Commercial Building & Restoration, Inc.

Commercialbuildrestoration.com  
Office 718-369-1001 Fax 718-369-7059

Brick ties specifications below

11:12

LTE

← 12345SVSEISVA.pdf



## Seismic Anchors and Ties 345-SV Seismic-Notch Veneer Anchor

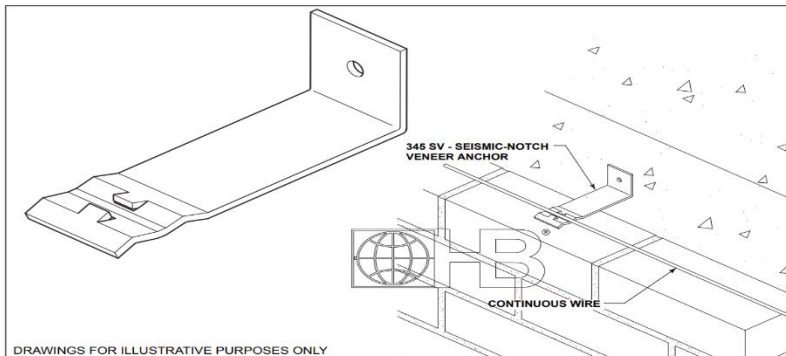

DRAWINGS FOR ILLUSTRATIVE PURPOSES ONLY

The **345-SV Veneer Anchor** features a Seismic Notch that accommodates 9 gauge or 3/16" continuous wire while providing superior pull-out strength.

**MATERIAL CONFORMANCE**  
**Wire (Carbon Steel):** Prefabricated from cold-drawn steel wire conforming to **ASTM A1064/A1064M**  
Tensile Strength - 80,000 psi | Yield Point - 70,000 psi minimum  
Zinc Coating:  
Hot-Dip Galvanized after fabrication: **ASTM A153/A153M-B** (1.5 oz/ft<sup>2</sup>)  
Note: Hohmann & Barnard will certify to a minimum of 2.0 oz/ft<sup>2</sup>

**Wire (Stainless Steel): ASTM A680/A680M - AISI Type 304 or Type 316**  
Zinc Coating:  
Hot-Dip Galvanized: **ASTM A153/A153M Class B** (1.5 oz/ft<sup>2</sup>) (sheet metal ties and anchors galvanized after fabrication)  
Note: Hohmann & Barnard will certify to a minimum of 2.0 oz/ft<sup>2</sup>

**Sheet Metal (Carbon Steel): ASTM A1008/A1008M**  
Zinc Coating:  
Hot-Dip Galvanized: **ASTM A153/A153M Class B** (1.5 oz/ft<sup>2</sup>) (sheet metal ties and anchors galvanized after fabrication)  
Note: Hohmann & Barnard will certify to a minimum of 2.0 oz/ft<sup>2</sup>

**Sheet Metal (Stainless Steel): ASTM A666, ASTM A480/480M, and ASTM A240/A240M - AISI Type 304 or Type 316**  
H&B manufactures steel wire products from a minimum of 95% recycled material.

**Finish:**  
 Hot-Dip Galv.    Stainless Steel:  Type 304     Type 316  
**Note: Hohmann & Barnard recommends Stainless Steel for maximum protection against corrosion.**

**Thickness:**  
 16 gauge  
 14 gauge  
 12 gauge

**Length:** \_\_\_\_\_

**Continuous Wire:**  9 gauge     3/16"Ø

**Standard Dimensions:** 345-SV is 1 1/2" wide x 16 ga., 14 ga., or 12 ga., and is available in any length with 3/32"Ø hole

**IMPORTANT:** Since each construction project is unique, the appropriate selection and use of any product contained herein must be determined by competent architects, engineers and other appropriate professionals who are familiar with the specific requirements of the project in question. This drawing and/or data sheet is the confidential and proprietary information of Hohmann & Barnard, Inc. and is not to be reproduced, copied or disclosed, in whole or in part, without the prior written consent of H&B.

**HOHMANN & BARNARD, Inc.**  
CORPORATE HEADQUARTERS  
30 Rasons Court | Hauppauge, NY 11788  
T: 800.645.0616 F: 631.234.0683  
[www.h-b.com](http://www.h-b.com)

**Branch/Subsidiary Locations:**  
ALABAMA - ARIZONA - ILLINOIS  
MARYLAND - NEW YORK  
PENNSYLVANIA - TEXAS - UTAH  
CANADA

© 2013-2017 MITek®

**PRINT FORM**  
**RESET FORM**    **SAVE FORM**  
**SAVE FORM LOCK & HIDE BUI...**



# Commercial Building & Restoration, Inc.

Commercialbuildrestoration.com  
Office 718-369-1001 Fax 718-369-7059

## Approved Mortar Documentation

Mon, Apr 3, 9:28 AM

to me, Chris, Richie, Mauricio

Hi Doug,  
The building is fine with your recommendation.  
Chris, please let us know if you have a different opinion.  
Thanks,  
James



**Douglas Gornick** <[commercialbuildingrestoration@gmail.com](mailto:commercialbuildingrestoration@gmail.com)>

Tue, Apr 4,  
9:00 AM

to James, Chris, Richie, Mauricio, me

Since time is of the essence CBR will order the Specmix #407.

Thank you, Doug

# Commercial Building & Restoration, Inc.

Commercialbuildrestoration.com  
Office 718-369-1001 Fax 718-369-7059

## LPC approval for the Terracotta coping

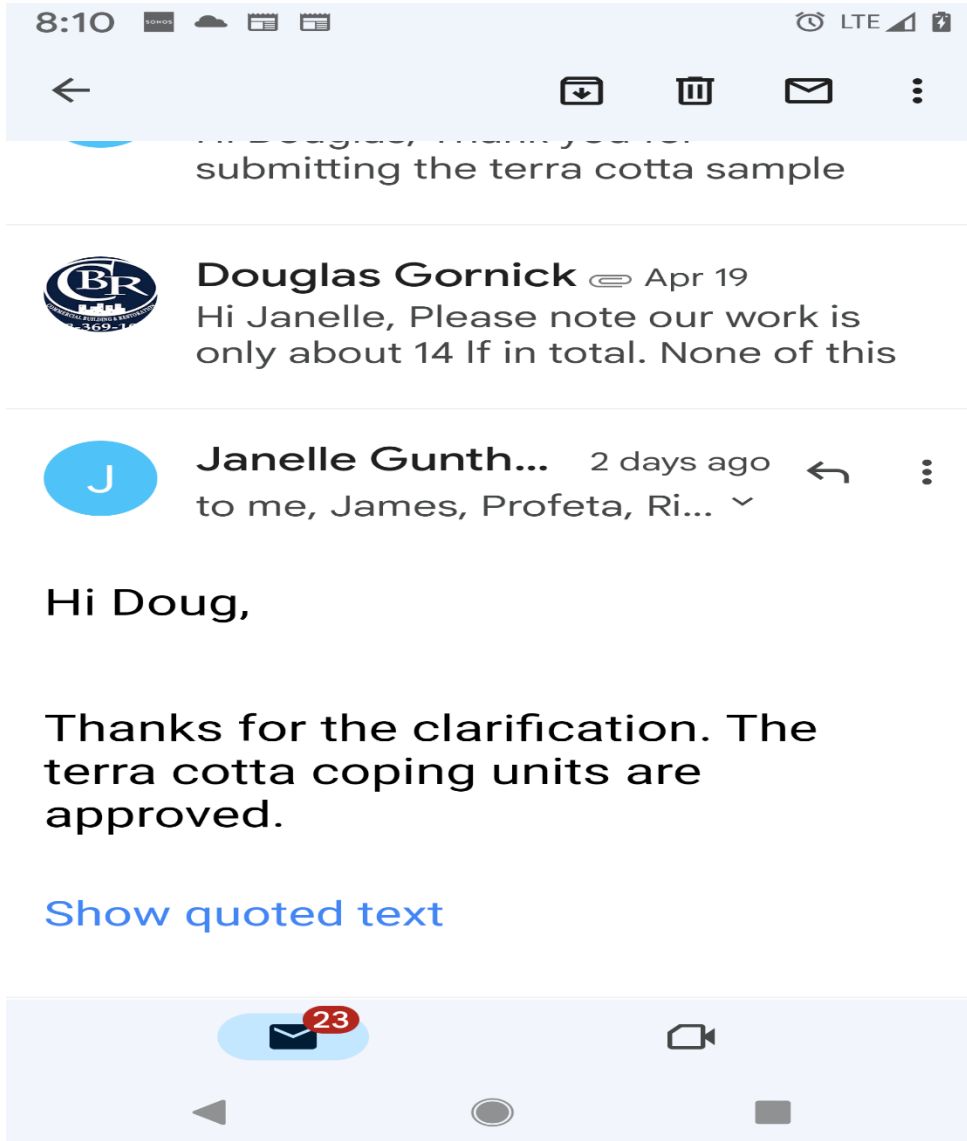

# Commercial Building & Restoration, Inc.

Commercialbuildrestoration.com  
Office 718-369-1001 Fax 718-369-7059

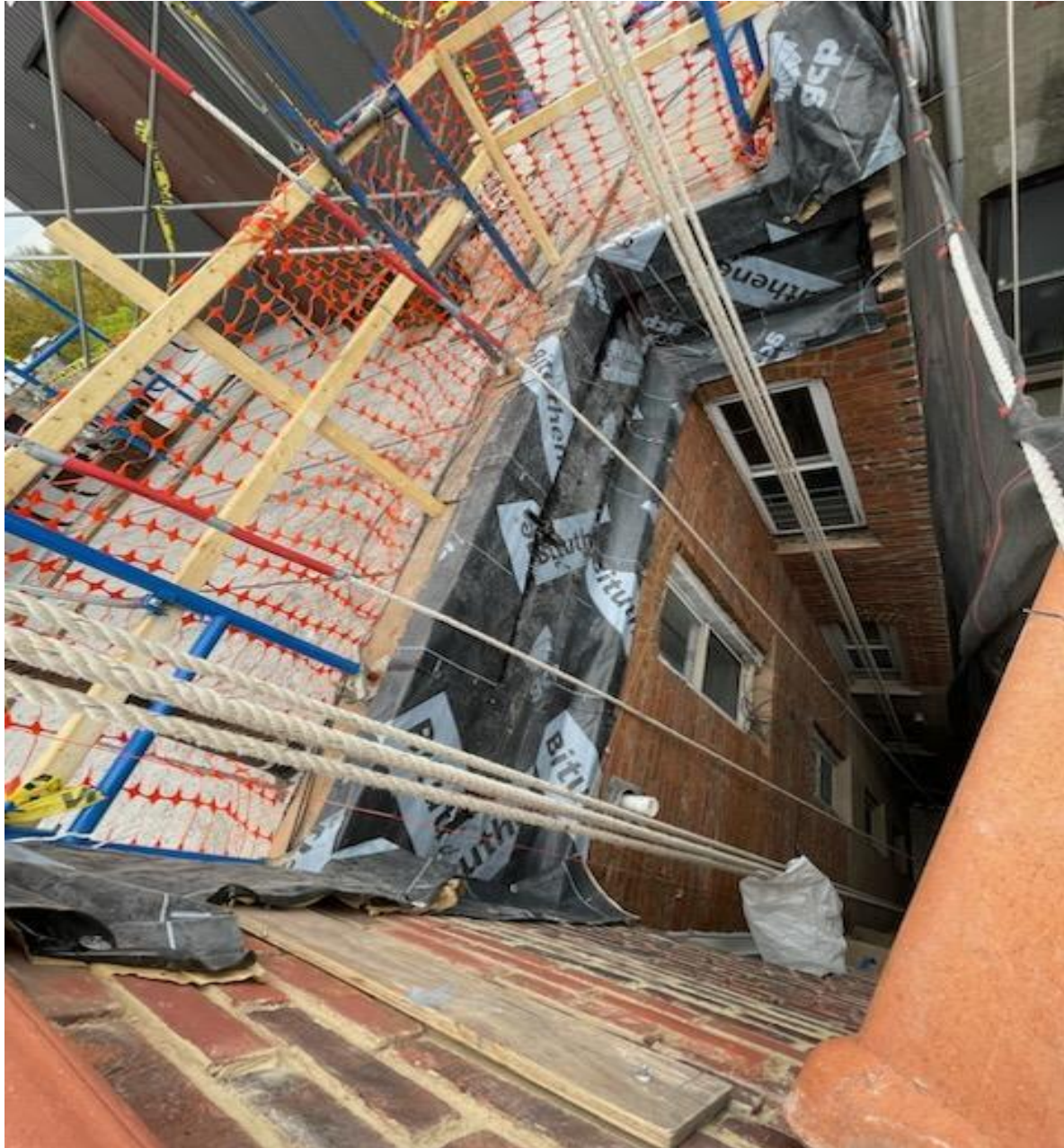

119 14<sup>th</sup> St, BROOKLYN NY 11215  
(718) 369-1001 F (718) 369-7059

# Commercial Building & Restoration, Inc.

Commercialbuildrestoration.com  
Office 718-369-1001 Fax 718-369-7059

**Sill waterproofing installed**



**Sill reinstated**



119 14<sup>th</sup> St, BROOKLYN NY 11215  
(718) 369-1001 F (718) 369-7059

# Commercial Building & Restoration, Inc.

Commercialbuildrestoration.com  
Office 718-369-1001 Fax 718-369-7059



**Note – ALL window caulk work is completed**

119 14<sup>th</sup> St, BROOKLYN NY 11215  
(718) 369-1001 F (718) 369-7059



# Commercial Building & Restoration, Inc.

Commercialbuildrestoration.com  
Office 718-369-1001 Fax 718-369-7059

**Parapet wall rebuilding work in progress**



**Level confirming straight wall**

**Approved change order for window capping is installed**



119 14<sup>th</sup> St, BROOKLYN NY 11215  
(718) 369-1001 F (718) 369-7059

# Commercial Building & Restoration, Inc.

Commercialbuildrestoration.com  
Office 718-369-1001 Fax 718-369-7059



119 14<sup>th</sup> St, BROOKLYN NY 11215  
(718) 369-1001 F (718) 369-7059

# Commercial Building & Restoration, Inc.

Commercialbuildrestoration.com  
Office 718-369-1001 Fax 718-369-7059

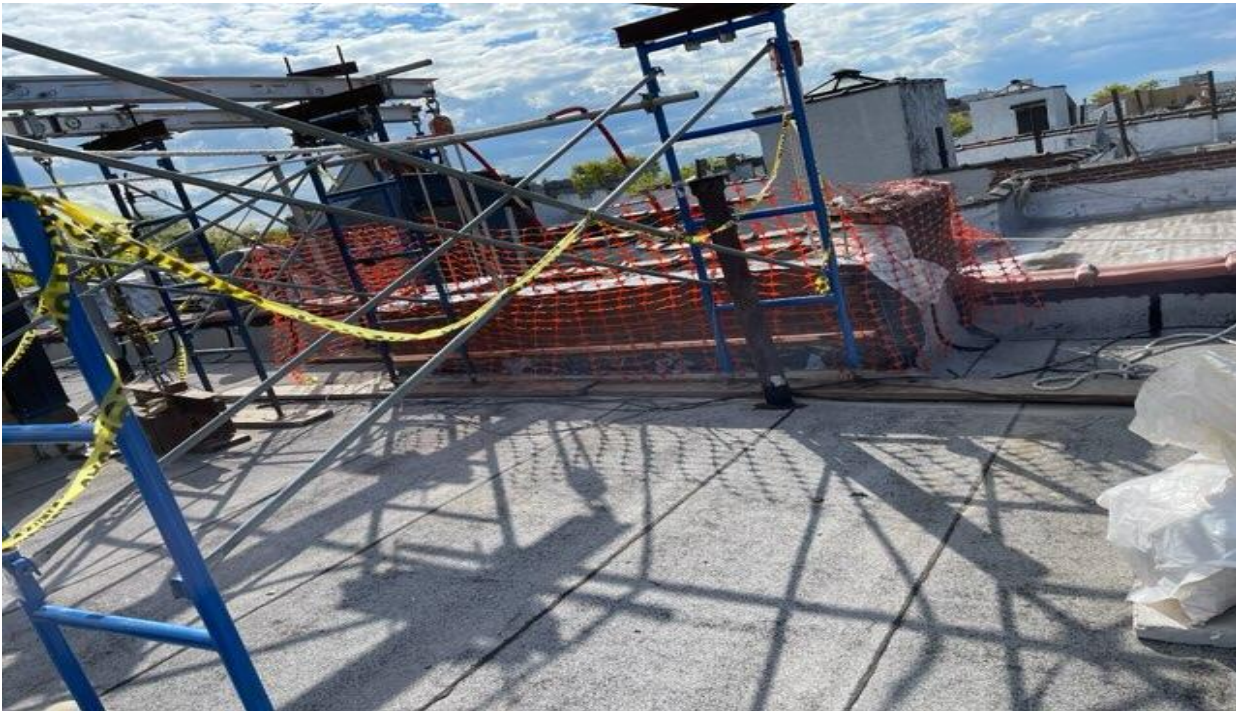

119 14<sup>th</sup> St, BROOKLYN NY 11215  
(718) 369-1001 F (718) 369-7059

# Commercial Building & Restoration, Inc.

Commercialbuildrestoration.com  
Office 718-369-1001 Fax 718-369-7059



119 14<sup>th</sup> St, BROOKLYN NY 11215  
(718) 369-1001 F (718) 369-7059

# Commercial Building & Restoration, Inc.

Commercialbuildrestoration.com  
Office 718-369-1001 Fax 718-369-7059



119 14<sup>th</sup> St, BROOKLYN NY 11215  
(718) 369-1001 F (718) 369-7059

# Commercial Building & Restoration, Inc.

Commercialbuildrestoration.com  
Office 718-369-1001 Fax 718-369-7059



119 14<sup>th</sup> St, BROOKLYN NY 11215  
(718) 369-1001 F (718) 369-7059

# Commercial Building & Restoration, Inc.

Commercialbuildrestoration.com  
Office 718-369-1001 Fax 718-369-7059

**Approved LPC camelback copings installed**



119 14<sup>th</sup> St, BROOKLYN NY 11215  
(718) 369-1001 F (718) 369-7059

# Commercial Building & Restoration, Inc.

Commercialbuildrestoration.com

Office 718-369-1001 Fax 718-369-7059



119 14<sup>th</sup> St, BROOKLYN NY 11215  
(718) 369-1001 F (718) 369-7059



# Commercial Building & Restoration, Inc.

Commercialbuildrestoration.com

Office 718-369-1001 Fax 718-369-7059



119 14<sup>th</sup> St, BROOKLYN NY 11215  
(718) 369-1001 F (718) 369-7059

# Commercial Building & Restoration, Inc.

Commercialbuildrestoration.com

Office 718-369-1001 Fax 718-369-7059



119 14<sup>th</sup> St, BROOKLYN NY 11215  
(718) 369-1001 F (718) 369-7059

# Commercial Building & Restoration, Inc.

Commercialbuildrestoration.com  
Office 718-369-1001 Fax 718-369-7059

**Additional dust control installed**



119 14<sup>th</sup> St, BROOKLYN NY 11215  
(718) 369-1001 F (718) 369-7059

# Commercial Building & Restoration, Inc.

Commercialbuildrestoration.com  
Office 718-369-1001 Fax 718-369-7059

**Cutting is done 100%. All pointing will be done 100% 5/15/23**



119 14<sup>th</sup> St, BROOKLYN NY 11215  
(718) 369-1001 F (718) 369-7059

# Commercial Building & Restoration, Inc.

Commercialbuildrestoration.com  
Office 718-369-1001 Fax 718-369-7059



119 14<sup>th</sup> St, BROOKLYN NY 11215  
(718) 369-1001 F (718) 369-7059

# Commercial Building & Restoration, Inc.

Commercialbuildrestoration.com

Office 718-369-1001 Fax 718-369-7059



119 14<sup>th</sup> St, BROOKLYN NY 11215  
(718) 369-1001 F (718) 369-7059

# Commercial Building & Restoration, Inc.

Commercialbuildrestoration.com  
Office 718-369-1001 Fax 718-369-7059



119 14<sup>th</sup> St, BROOKLYN NY 11215  
(718) 369-1001 F (718) 369-7059

# Commercial Building & Restoration, Inc.

Commercialbuildrestoration.com  
Office 718-369-1001 Fax 718-369-7059



**All contracted masonry and parapet wall is completed**

**5/15/23**

**Douglas Gornick**